



Analog C-FLUOR

SUBMERSIBLE PROBES

User's Manual



January 18, 2021
P/N 998-2123
Revision 2.0

TURNER DESIGNS
1995 N. 1st Street
San Jose, CA 95112
Phone: (408) 749-0994
FAX: (408) 749-0998

Table of Contents

1. Introduction	
1.1 Description	4
2. Inspection and Setup	
2.1 Instrument Checklist	5
2.2 Configurations	5
2.3 Optional Accessories	5
2.4 Functional Test for C-FLUOR with connector	7
3. Measurements with the C-FLUOR	
3.1 Introduction	8
3.2 Determine a Different Offset	8
3.3 Determine a Different Calibration Coefficient	8
3.4 Performing C-FLUOR Measurements	9
4. Maintenance and Warranty	
4.1 Maintenance	10
4.1.1 Rinsing	10
4.1.2 Care for the bulkhead connector	10
4.1.3 Care for the Optics	10
4.2 Warranty Terms	10
4.3 Warranty Service	11
4.4 Out of Warranty Service	11
Appendices	
A Specifications	13
B Recommended Lab Measurement Practices	14
C Wiring Guide	15
D Pigtail Cable and Connector Information	16
E Linear Range, Quenching and Temperature Considerations	17
F Functional Test for C-FLUOR with No Connector	18
G Using the C-FLUOR Submersible Probe with the DataBank	19

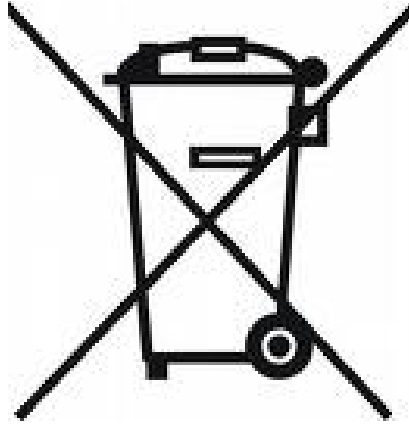

WASTE ELECTRICAL AND ELECTRONIC EQUIPMENT (WEEE) DIRECTIVE

Turner Designs is in the business of designing and selling products that benefit the well-being of our environment. Accordingly, we are concerned with preserving the surroundings wherever our instruments are used and happy to work with customers by complying with the WEEE Directive to reduce the environmental impact resulting from the use of our products.

WEEE Return Process:

To arrange the return of an end-of-life product, proceed as follows:

If you purchased your instrument through a Turner Designs Distributor please contact your local representative. They will instruct you where to return the end-of-life product.

If you purchased your instrument directly from Turner Designs please contact Turner Designs Customer Service

By Phone: 1-408-212-4041 or Toll Free: (877) 316.8049

By Email: Customer Service at support@turnerdesigns.com

Turner Designs will provide a WEEE RMA Number, a Shipping Account Number, and a Ship to Address. Package and ship the product back to Turner Designs.

The product will be dealt with per Turner Designs' end-of-life recycling program in an environmentally friendly way.

C-FLUOR Submersible Probe

1. Introduction

1.1 Description

The Turner Designs C-FLUOR Submersible Probe is an accurate single-channel detector that can be used for many different applications. It is designed for integration into multi-parameter systems from which it receives power and delivers a voltage output proportional to the concentration of the fluorophore, particle, or compound of interest.

C-FLUOR is factory calibrated and includes a probe-specific calibration certificate with each C-FLUOR probe. The certificate contains calibration values that are used to convert voltage to concentration estimates.

C-FLUOR is manufactured with a Titanium housing and connector, ideal for long-term deployments and able to withstand most corrosive environments. It is available without a connector for integration flexibility; see Section 2.2 for part numbers.

NOTE: C-FLUOR cannot be used with the C6 Multi-Sensor Platform.

C-FLUOR Submersible Probe

2. Inspection and Setup

2.1 Instrument Checklist

The C-FLUOR Submersible Probe shipment package consists of:

- C-FLUOR Submersible Probe:
Configured and factory calibrated for the specified fluorophore or material as noted by the Identification Letter stamped on the connector:
 - “C” = Chlorophyll
 - “R” = Rhodamine
 - “F” = Fluorescein
 - “P” = Phycocyanin
 - “E” = Phycoerythrin
 - “U” = CDOM / FDOM
 - “O” = Crude Oil
 - “B” = Optical Brighteners
 - “T” = Turbidity
 - “D” = Red Excitation Chlorophyll
- Calibration Certificate
- Quick Start Guide
- USB Flash Drive if accessories are ordered.

2.2 Configurations

- C-FLUOR P/N: 2120-000-“Identification Letter”
- No Connector C-FLUOR P/N: 2120-000-“Identification Letter”-NC

Note: No end cap is supplied for the No Connector C-FLUOR. For end cap specifications, contact Support@turnerdeisngs.com

2.3 Optional Accessories

- [Pigtail Cables with Locking Sleeve](#) - see Appendix D for more information
 - 0.6 meter Pigtail Cable with Locking Sleeve P/N 2100-750
 - 5 meter Pigtail Cable with Locking Sleeve P/N 2100-755
 - 10 meter Pigtail Cable with Locking Sleeve P/N 2100-751
 - 25 meter Pigtail Cable with Locking Sleeve P/N 2100-752
 - 50 meter Pigtail Cable with Locking Sleeve P/N 2100-753



Note: Pigtail Cables should NOT be used to tow instruments.

- [DataBank Handheld Data Logger](#) P/N: 2900-199 - see Appendix G
- [Flow Cap](#) P/N: 2100-600 - see Accessory Instructions on USB Flash Drive
- [Shade Cap](#) P/N: 2100-701 - see Accessory Instructions on USB Flash Drive

C-FLUOR Submersible Probe

Note: We recommend use of the shade cap as it provides a fixed distance for sample measurement and minimizes effects from ambient light.

- [Explorer](#) P/N: 2100-485 – see Accessory Instructions on USB Flash Drive
- [Solid Secondary Standard \(SSS\) for *in vivo* Chlorophyll, Phycocyanin, Phycoerythrin, Rhodamine, Fluorescein](#) P/N: 2100-900 - see Accessory Instructions on USB Flash Drive

Note: The SSS can be used for both C-FLUOR and Cyclops for the applications specified above.

- [Solid Secondary Standard \(SSS\) for UV](#) - CDOM / FDOM, Optical Brighteners, and Crude Oil P/N: 2100-904 - see Accessory Instructions on USB Flash Drive

Note: The UV SSS can be used for both C-FLUOR and Cyclops for the applications specified above, as well as Cyclops Refined Fuels and Tryptophan sensors.



Shade Cap



Flow Cap



Solid Secondary Standard

C-FLUOR Submersible Probe

2.4 Functional Test for C-FLUOR with connector

To perform a functional check on a C-FLUOR Probe, connect the Pigtail's colored wires to the power supply and multi-meter as shown in Figure 1 below.

Additional Equipment required for functional tests:

DC Power Supply, 3 - 15 VDC, >100 mA

Multi-meter to read 0 – 5 VDC



Note: Supply voltages greater than 15 VDC will damage the probe.

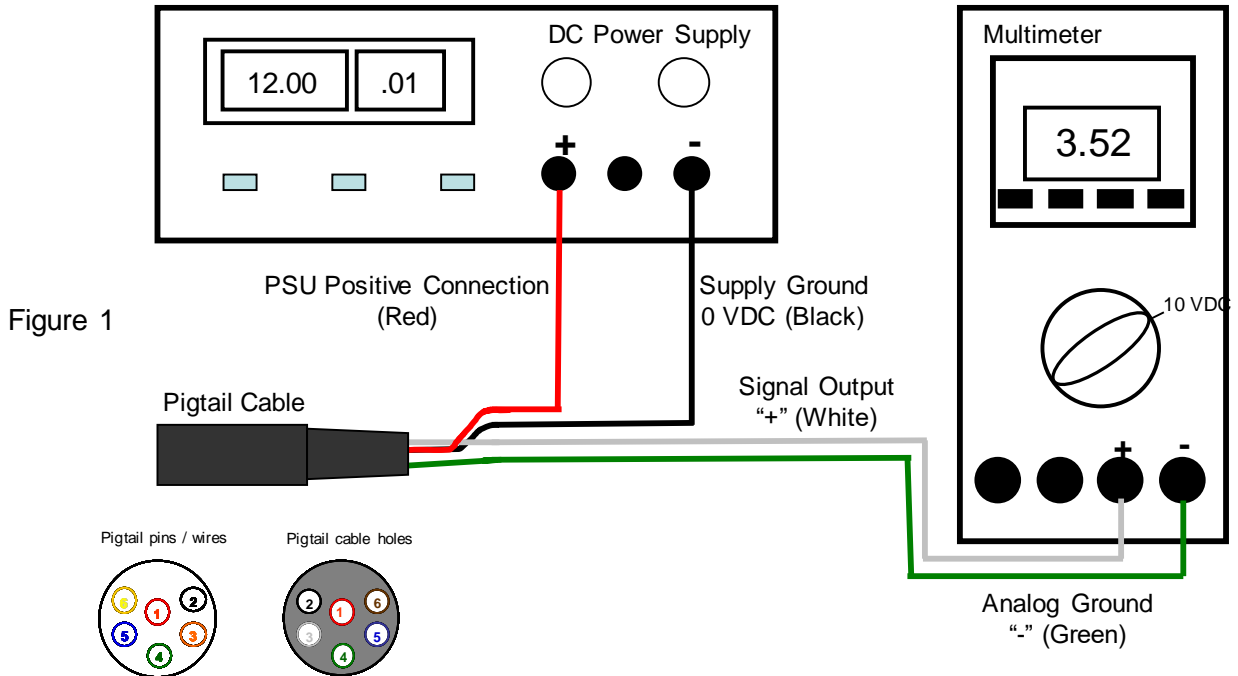

With the C-FLUOR connected as shown in Figure 1, answer questions 1-3 by making the following functional tests:

1. Is the LED on?
Hold a piece of white paper about $\frac{1}{2}$ an inch in front of the optical head to ensure the LED is ON.
Note: This test does not work for Turbidity probes because they use infrared which is not visible.
2. Is there voltage output?
The multi-meter should be reading some voltage >0 VDC
3. Does the voltage output change?
Move the light source closer to the piece of paper and check if the voltage output increases

C-FLUOR Submersible Probe

3. Measurements with the C-FLUOR

3.1 Introduction

The following information will describe how to:

- Determine a Different Offset – ONLY REQUIRED IF CHANGING FACTORY OFFSET
- Determine a Different Calibration Coefficient– ONLY REQUIRED IF CHANGING FACTORY CALIBRATION
- Perform C-FLUOR Measurements

Note: To make accurate and repeatable measurements it is important to keep the probe clean; see Section 4.1 for information regarding maintenance.

C-FLUOR Probes output a voltage signal that is proportional to the fluorophore of interest. Every C-FLUOR is factory calibrated and delivered with a certificate that contains factory calibration values for that specific probe; the certificate also contains an equation that can be used with the calibration values to convert C-FLUOR's voltage signal to concentration estimates for the specified fluorophore of interest.

For increased accuracy when estimating fluorophore concentrations you can create user-defined calibration values. Sections 3.2 and 3.3 explain how to derive your own calibration values for your environment or fluorophore of interest. **If you want to use the factory calibration, skip to Section 3.4.**

3.2 Determine a Different Offset

C-FLUOR's Factory Offset is measured using ultra-pure water. When working in an environment where background fluorescence values are greater than the factory measured Offset, you may want to consider using an Offset that is more suited for your water type. To determine an Offset for your water type:

- 1) Collect a sample of water that represents the water type you will be measuring.
- 2) Remove the fluorophore of interest from that water sample. For example, for *in vivo* chlorophyll you would filter the water sample through a GF/F or like filter to remove all algal cells from the sample.
- 3) Once the fluorophore of interest has been removed from the water sample, measure that sample using the C-FLUOR and record the voltage response.
- 4) Your Offset will be equal to that voltage response so all voltage measurements for that water type should have this Offset subtracted.

3.3 Determine a Different Calibration Coefficient

The Calibration Coefficient stated on the calibration certificate is a correlation between a standard of known concentration and the Offset-corrected response for that standard. To create your own calibration coefficient:

- 1) Determine an Offset for your water type - see Section 3.2.
- 2) Obtain a standard that
 - a. Has a known concentration.

C-FLUOR Submersible Probe

- b. Falls within the measuring range of the C-FLUOR.
- 3) Measure the response of that standard.
- 4) Subtract the Offset from that measured response.
- 5) Divide the concentration of the standard by its Offset-corrected response.
- 6) Your result is a calibration coefficient that can be used to convert Offset-corrected voltages to direct concentrations.

3.4 Performing C-FLUOR Measurements

C-FLUOR Probes output a 0-5 Volt analog signal proportional to the fluorescence detected from the fluorophore of interest. Use the wiring diagram from Section 2.4 to connect the C-FLUOR to a power supply and a multi-meter or datalogger that will read voltages from the probe. Submerge the optical head, or entire probe, into the water sample; the voltage displayed indicates the relative amount of fluorophore in your sample. Correct the measured voltage by subtracting the Offset and then multiply by the determined Calibration Coefficient to calculate fluorophore concentration.

If reading samples in a container, see Appendix B for recommended measurement practices.

C-FLUOR Probes can be integrated into any third party system that is capable of supplying 3 – 15 VDC and accepting a 0-5 Volt analog signal.

C-FLUOR Submersible Probe

4. Maintenance and Warranty

4.1 Maintenance

4.1.1 Rinsing

The C-FLUOR should be rinsed or soaked in fresh water following each deployment until it is completely clean again.

4.1.2 Care for the bulkhead connector

A light coat of Silicone spray should be used on the rubber of the male pins of the bulkhead to aid in sealing. The manufacturer recommends 3M™ Silicone Lubricant Spray or Loctite 8021 spray.

Note: You should avoid using silicone grease. Do NOT use WD-40, it will destroy the connectors.

4.1.3 Care for the optics

The optical window should be visually inspected after each deployment following a soaking in fresh water. If cleaning is needed, use optical tissue to clean the window with soapy water.



Note: The C-FLUOR should NOT come in contact with any organic solvents (i.e. acetone, methanol) or strong acids and bases.

4.2 Warranty Terms

Turner Designs warrants the C-FLUOR and accessories to be free from defects in materials and workmanship under normal use and service for a period of 12 months from the date of shipment from Turner Designs with the following restrictions:

- Turner Designs is not responsible for replacing parts damaged by accident or neglect. Your instrument must be installed according to instructions in the User's Manual. Damage from corrosion is not covered. Damage caused by customer modification of the instrument is not covered.
- This warranty covers only Turner Designs products and is not extended to equipment used with our products. We are not responsible for incidental or consequential damages, except in those states where this limitation is not allowed. This warranty gives you specific legal rights and you may have other rights which vary from state to state.
- Damage incurred in shipping is not covered.

C-FLUOR Submersible Probe

4.3 Warranty Service

To obtain service during the warranty period, the owner shall take the following steps:

1. Write, email or call Turner Designs Technical Support and describe as precisely as possible the nature of the problem.

Phone: 1 (877) 316-8049

Email: support@turnerdesigns.com

2. Carry out any adjustments or tests as suggested by Technical Support.
3. If proper performance is not obtained you will be issued a Return Materials Authorization number (RMA) to reference. Package the unit, write the RMA number on the outside of the shipping carton, and ship the instrument, prepaid, to Turner Designs. If the failure is covered under the warranty terms the instrument will be repaired and returned free of charge, for all customers in the contiguous continental United States.

For customers outside of the contiguous continental United States who purchased equipment from one of our authorized distributors, contact the distributor. If you purchased directly, contact us. We will repair the instrument at no charge. Customer pays for shipping, duties, and documentation to Turner Designs. Turner Designs pays for return shipment (custom duties, taxes and fees are the responsibility of the customer).

4.4 Out-of-Warranty Service

Follow steps for Warranty Service as listed above. If Technical Support can assist you by phone or correspondence, we will be glad to, at no charge. Repair service will be billed on a fixed price basis, plus any applicable duties and/or taxes. Shipment to Turner Designs should be prepaid. Your bill will include return shipment freight charges.

Address for Shipment:

Turner Designs, Inc.
1995 N. 1st Street
San Jose, CA 95112

C-FLUOR Submersible Probe

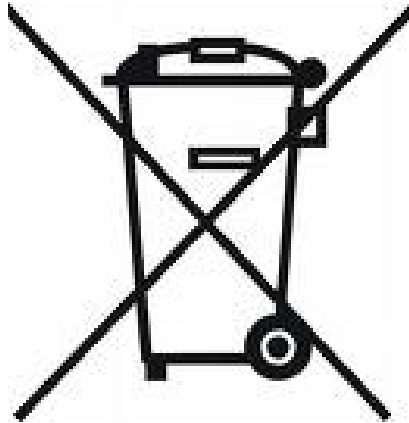

C-FLUOR Submersible Probe

Appendix A: Specifications

Parameter	Specification	
Full Range Linearity	0.99 R ²	
Power Draw @ 12V	CHL, RWT, PC, PE, F, CDOM/fDOM, Oil, OB = 12mA Turbidity = 10mA Red Excitation CHL = 16mA	
Input Voltage	3 – 15 VDC	
Signal Output	0 – 5 VDC Analog	
Temperature Range	Ambient: 0 to 50 °C Water Temp: -2 to +50 °C	
Light Source	Light Emitting Diode	
Excitation Wavelength	Visible – CHL, RWT, PC, PE, F UV – CDOM/fDOM, Oil, OB IR – Turbidity	
Detector	Photodiode	
Detection Wavelengths	400 – 850 nm	
T99	<0.6 seconds	
Housing Material	Titanium	
Dimensions	C-FLUOR L: 5.2 in., 13.24 cm D: 0.875 in., 2.23 cm	No Connector C-FLUOR L: 3.8 in., 9.68 cm D: 0.875 in., 2.23 cm
Depth Rating	2,000 meters	
Weight	3.1 oz; 89 gm	

C-FLUOR Submersible Probe

Appendix B: Recommended Lab Measurement Practices

Recommended Lab Practices for Measurements

The following steps will improve the accuracy and repeatability of your measurements, especially at low concentration levels:

1. Use a non-fluorescent container for your water samples. **Note: Plastic may fluoresce and interfere with the sample's fluorescence.**
2. If using a glass container, place the container on a non-reflective black surface.
3. Ensure that the probe is more than 3 inches above the bottom of the container.
4. Ensure that the probe is in the center of the container and has more than 2 inches clearance between the circumference of the probe and the inside surface of the beaker.

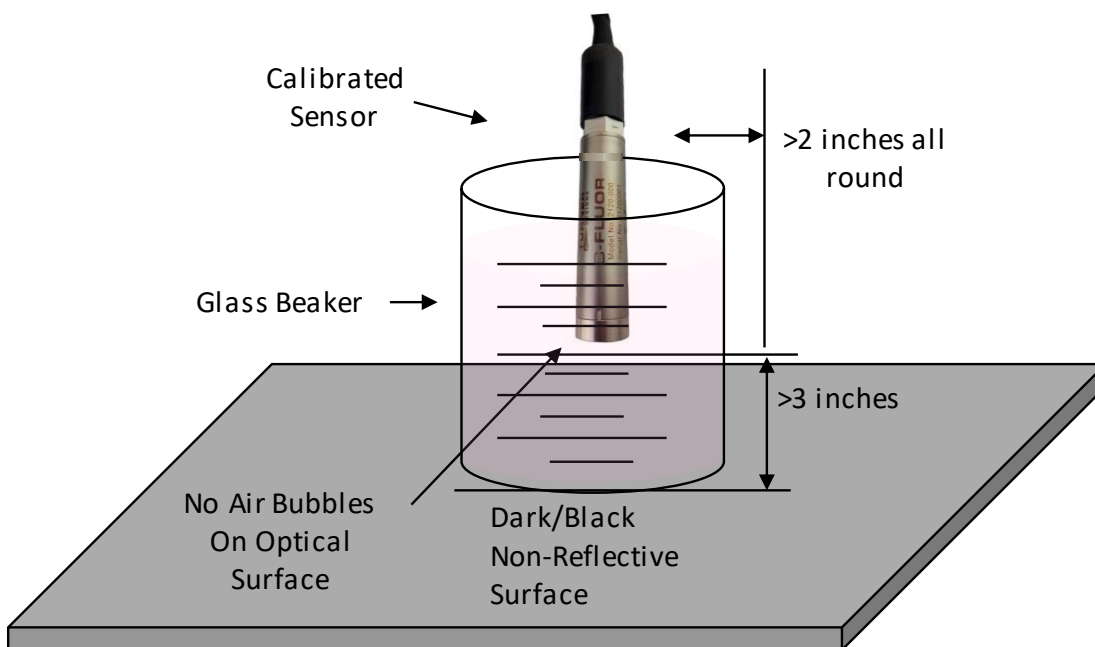

C-FLUOR Submersible Probe

Appendix C: Wiring Guide

C-FLUOR Pins/Wires	Pin Number	Function	Connection
Red	1	Supply Voltage 3 – 15 VDC	PSU – Positive Connection
Black	2	Supply Ground, 0VDC	PSU – Ground Connection
Orange	3	Signal Out to data logger “+” 0 – 5VDC	Multimeter Positive Connection
Green	4	Analog Ground “-”, 0 VDC	Multimeter Negative Connection

C-FLUOR Pins
and Wire Color

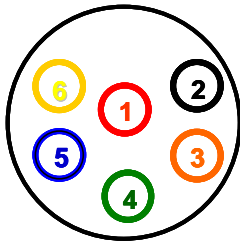

Pigtail Connector
and Wire Color

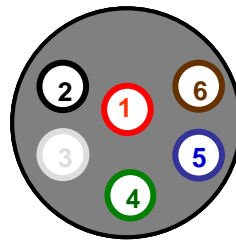

Note: Pins 5 and 6 are not used.

C-FLUOR Submersible Probe

Appendix D: Pigtail Cable and Connector Information

Dimension details of 24" length cable with 20 gauge colored lead wire, connects to 6 pin male connector. (Cable manufacturer/Part No: IMPULSE/MCIL-6-FS)

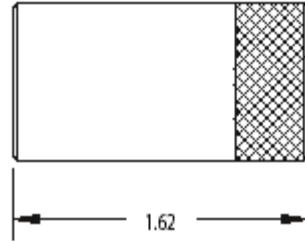
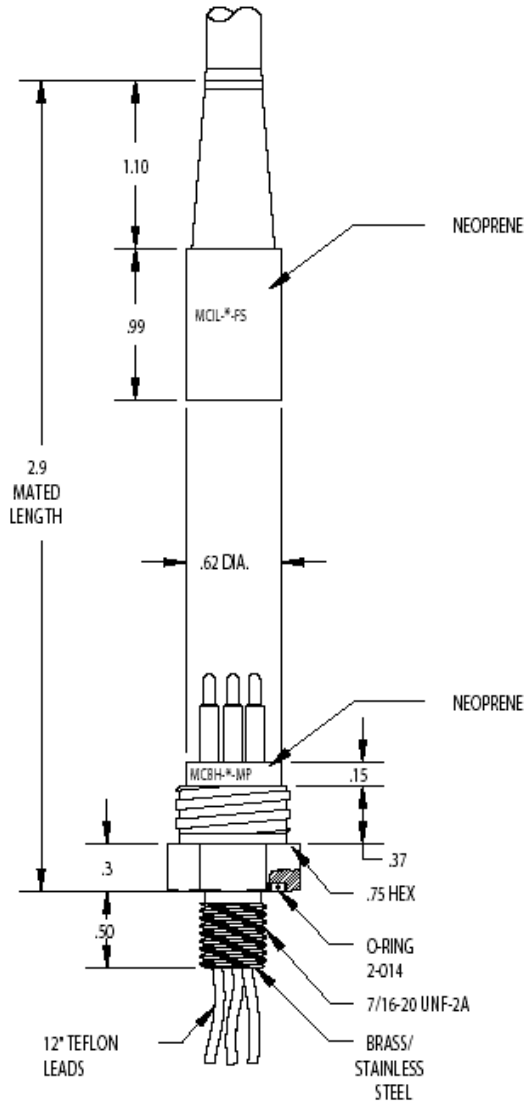

Female locking sleeve,
(Impulse P/No. MCDLS-F)

C-FLUOR Pins
and Wire Color

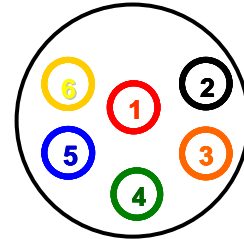

Pigtail Connector
and Wire Color

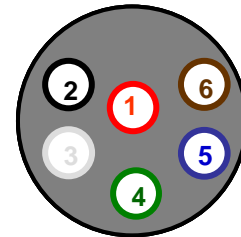

A maximum cable length up to 100 meters can be connected to the C-FLUOR if the following conditions are met:

- 1) The cable is shielded and contains 20 gauge conductor size or greater (i.e. Beldon No. 8426 cable).
- 2) The 0-5 volt Analog output is connected to a device (i.e. Data Logger) with an input impedance of 1 MegOhm or greater.
- 3) The supply Voltage to the C-FLUOR is between 5 and 15 volts.

C-FLUOR Submersible Probe

Appendix E: Linear Range, Quenching and Temperature Considerations

The linear range is the concentration range in which the fluorometer's output is directly proportional to the concentration of the signal. The linear range begins with the smallest detectable concentration and spans to an upper limit (concentration) that is dependent upon the properties of the material, filters used, and path length.

A non-linear relationship is seen at very high concentrations where the signal does not increase at a constant rate in comparison to the change in concentration - see figure below. At even higher concentrations, the signal will decrease even though the sample concentrations are continuing to increase. This effect is known as "signal quenching".

Linearity can be checked by diluting a sample 1:1 or some other convenient ratio. If the sample is still in the linear range, the reading will decrease in direct proportion to the dilution. If the reading does not decrease in direct proportion to the dilution, or if the reading increases, the sample is beyond the linear range.

Temperature Considerations

Fluorescence is temperature sensitive. As the temperature of the sample increases, the fluorescence decreases. For greatest accuracy, record the sample temperature and correct the probe output for changes in temperature.

For further information on how temperature, light, water quality and the physiological state of the algal cells can all affect measurements. Please refer to the Frequently Asked Questions in [Technical Support](#) on Turner Designs' website for more information about temperature compensation.

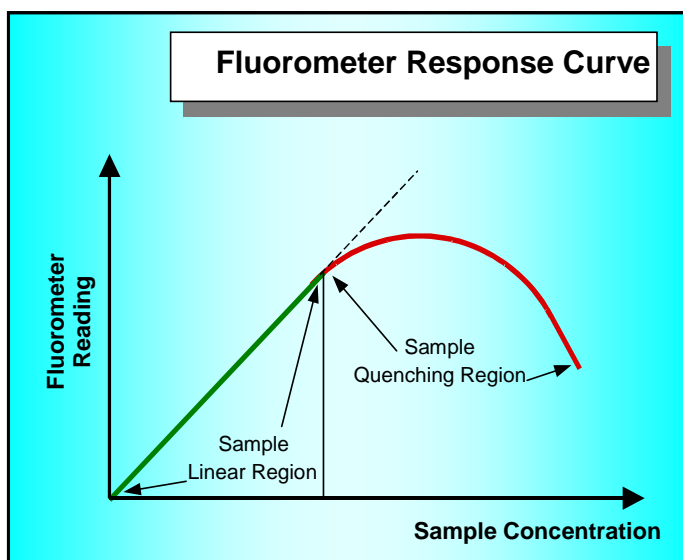

Graph showing Linear and Quenching Regions of the sample's response

C-FLUOR Submersible Probe

Appendix F: Functional Test for C-FLUOR with No Connector

To perform a functional check on the C-FLUOR, connect the C-FLUOR's colored wires to the power supply and multi-meter as shown in Figure 2 below.

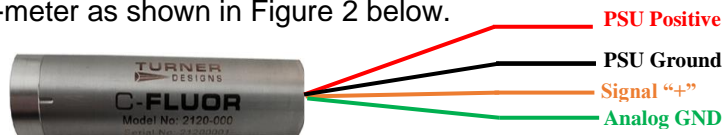

No Connector C-FLUOR (P/N: 2120-000-“Identification Letter”-NC)

Note: No end cap is supplied for the No Connector C-FLUOR. For end cap specifications, contact Support@turnerdeisngs.com

Additional Equipment required for functional tests:

DC Power Supply, 3 - 15 VDC, >100 mA

Multi-meter to read 0 – 5 VDC



Note: Supply voltages greater than 15 VDC will damage the probe.

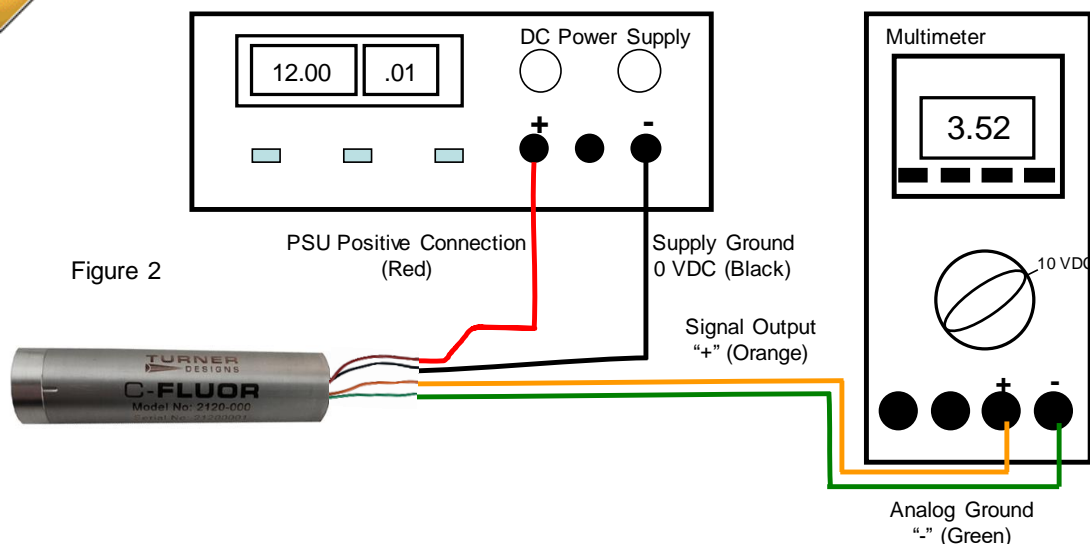

Figure 2

With the C-FLUOR connected as shown in Figure 1 answer questions 1-3 by making the following functional tests:

4. Is the LED on?
Hold a piece of white paper about ½ an inch in front of the optical head to ensure the LED is ON.
Note: This test does not work for Turbidity probes because they use infrared which is not visible.
5. Is there voltage output?
The multi-meter should be reading some voltage >0 VDC
6. Does the voltage output change?
Move the light source closer to the piece of paper and check if the voltage output increases

C-FLUOR Submersible Probe

Appendix G: Using the C-FLUOR Submersible Probe with the DataBank

C-FLUOR Probes are analog output devices that produce a 0 – 5 Volt signal proportional to the fluorophore being measured. Turner Designs offers the DataBank, a universal handheld meter, datalogger, and power supply that can be used to maximize performance of C-FLUOR Probes with functions such as:

- User defined calibrations
- Integrated Internal GPS
- Large internal memory
- Interval logging

The DataBank comes with intuitive GUI software that allows users to easily calibrate, set up logging, download data, and define parameters and values necessary to help configure the C-FLUOR for a specific application or study. Available options include travel case, and car charger.

DataBank uses for different sampling protocols:

Multiple Site Measurements – measure fluorescence at different locations within your water system or across many systems; GPS provides latitude/longitude data per location

Profiling – purchase extended cables to allow for vertical profiling

Monitoring – deploy the C-FLUOR to a fixed location or depth and monitor the signal over time; set up logging to capture a signal within a specific time frame; download data while the probe is deployed and continuously measuring; set up digital data output via HyperTerminal

For any application or sampling protocol, the DataBank facilitates and maximizes performance of all C-FLUOR Probes allowing versatility and flexibility in calibration, setup, and measurement.

